

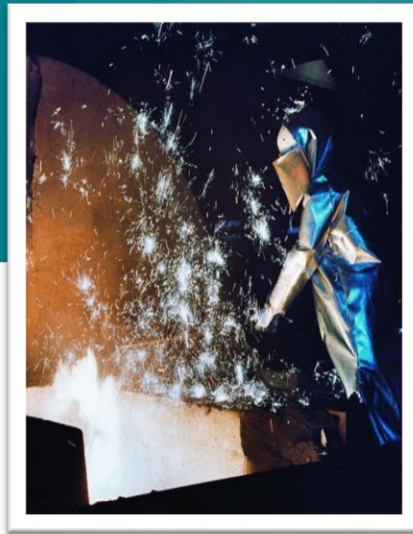

Gas Analyzer Solutions for the Iron and Steel Producing Industries



Steel Application Requirements – First we need to know the challenges

Technique Requirements:

Environmental conditions:

- Temperature
- Space
- Dust



• Analytical Requirements:

- All the Gases are saturated with moisture
- Coal tar presence in the Gas
- (up to 50 mg/m³)
- Dust Content is very High
- Also present ammonia and naphthalene in some cases

Traditional' Solution have limitations !!!!

STEEL Process Overview

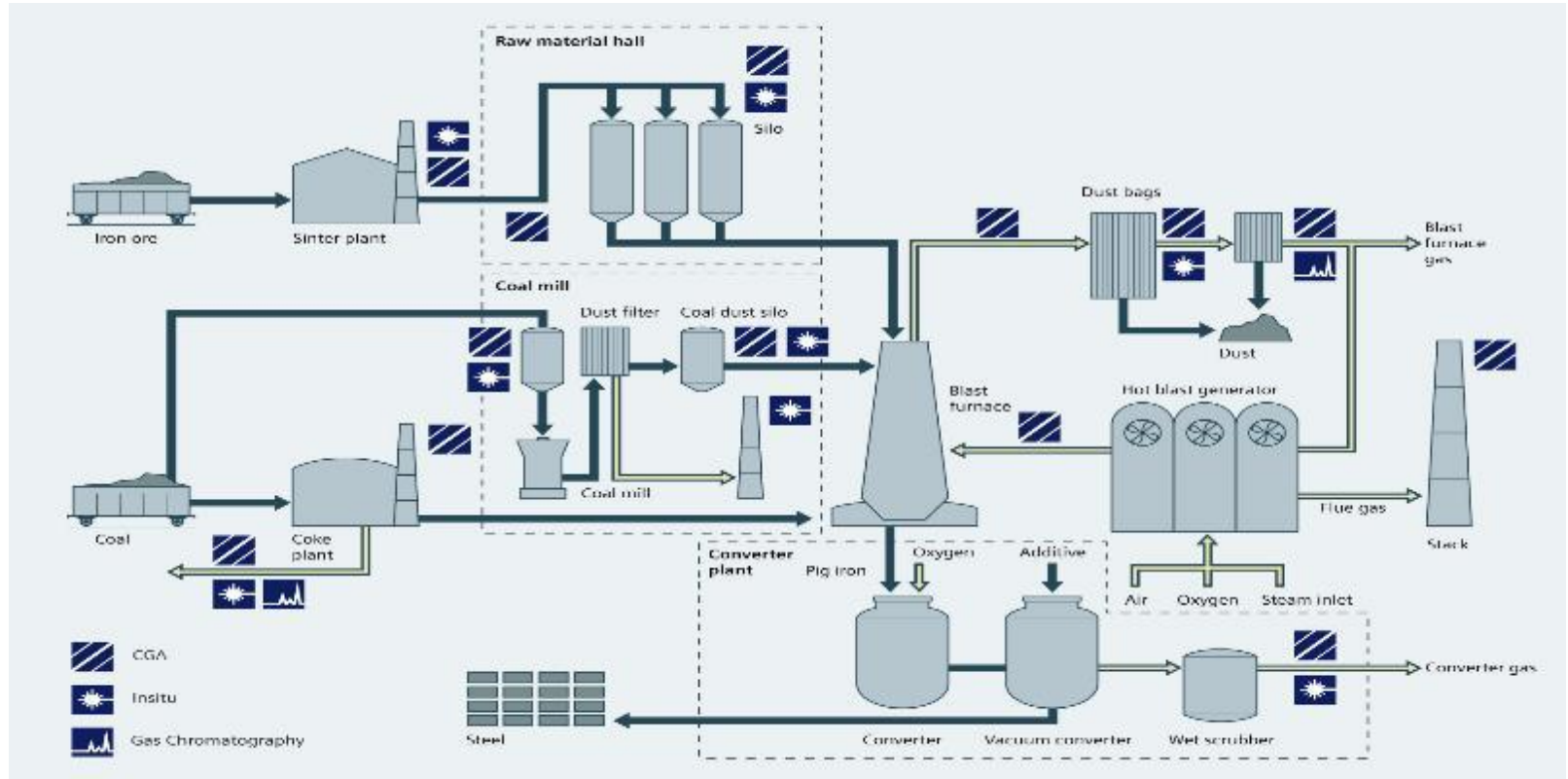

Application for Steel Plants

- Gas Analytical Application In Blast Furnaces
- Gas Analytical Application In LD Convertors
- Gas Analytical Application In Coke Ovens
- Gas Analytical Application In Power Plants
- Gas Analytical Application In Cold Rolling Mill
- Gas Analytical Application In Hot Strip Mill
- Gas Analytical Application In Sinter Plants
- Gas Analytical Application In Lime kiln

.....**and many more**



Application for Blast furnaces

- CO/CO₂ measurement in Above Burden
- CO/CO₂ measurement in In Burden
- CO/CO₂ & H₂ measurement Top Gas Analysis System
- O₂ Measurement in Cold Blast
- CO & O₂ Measurement in Stove Waste Gas
- CO/ SO_x / NO_x Measurement in Chimney
- Moisture Measurement in Cold Blast
- CO & O₂ Measurement in Coal Mill
- Calorific Value Measurement

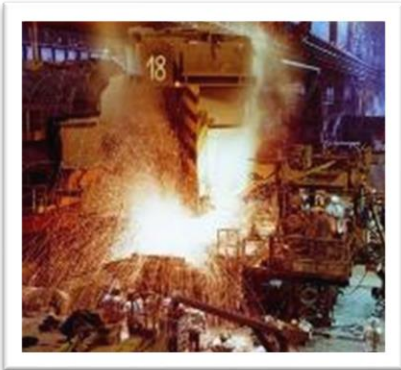

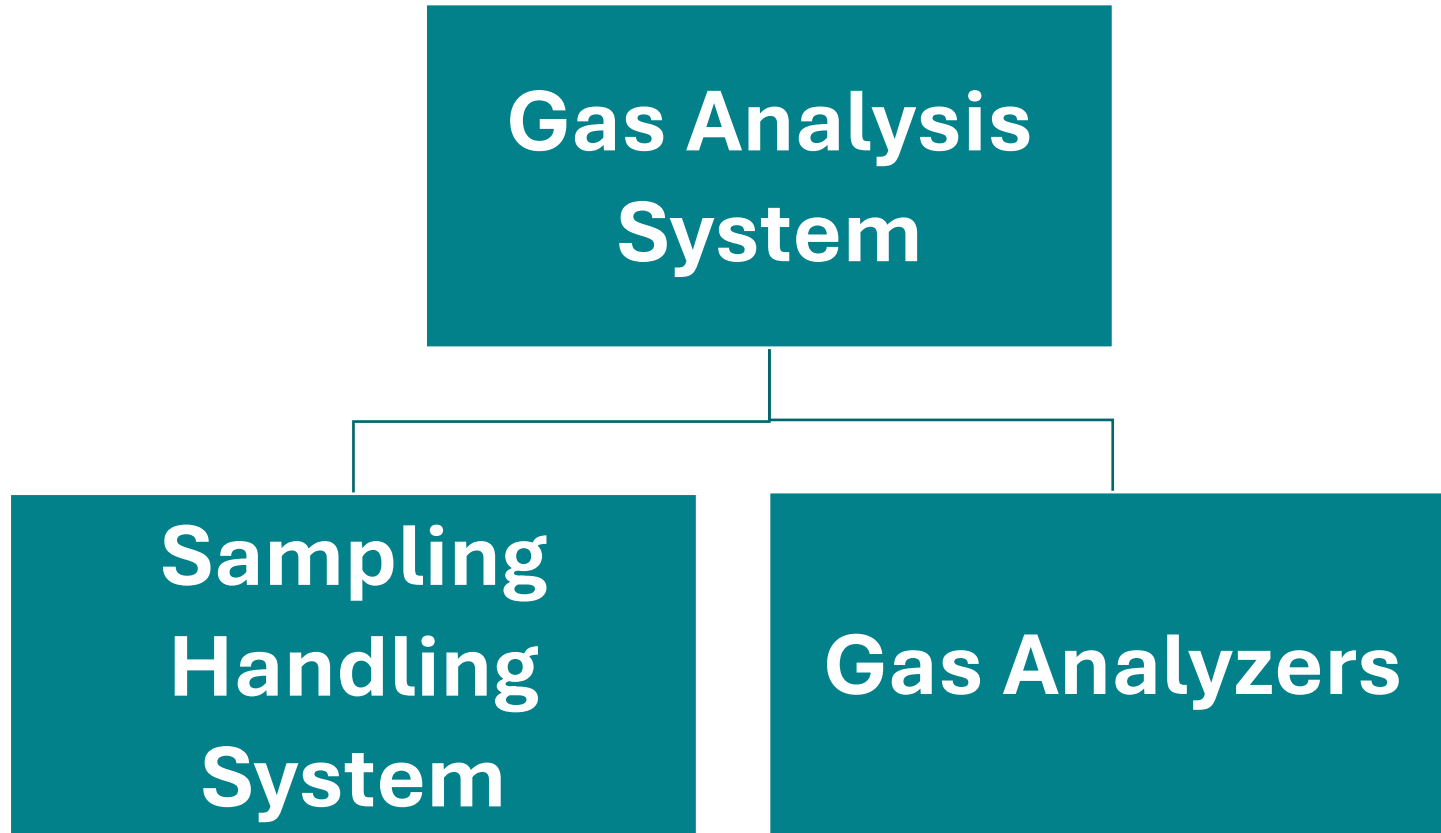

Challenges for Gas Analysis System in Blast Furnaces

Gas sampling systems in Steel Plant must be able to withstand a very tough environment:

High gas temperature

High Pressure of Sample Gas

High Moisture Content

High dust concentration

High content of Alkalis, Sulfates and Chlorides

High level of mechanical stress and strain

Leakages in System

Important Points in Designing the Gas Analysis System For Steel Plants

- The Process cannot be stopped. The System designed should be such that in case of any issues the System should run.
- The Sampling point should be redundant. So that in any point of time if one Probe has a problem the other probe should be able to operate the System. There should be no sampling Stoppages.
- The Filters should be chosen keeping the Sampling point in mind.
- There should be a minimum of 3 stages of filtration in the System
- A Heated Sample Line is also a must as the sample is loaded with moisture.
- Transportation time should be reduced to an optimum
- Now that the Sample is there in Panel The Analysers should be kept totally independent, so that in case of a failure / issue with one Analyser the readings of the other Analyser should be always available for the operation to continue the process.

Top Gas Analysis System

Challenges

- The Sample Gas is Raw Sample Gas with High Temperature
- The Dust content is High
- There is High Moisture.
- The Gas is sometimes at elevated pressure sometimes the pressure is low, depending on the tapping point.

Top Gas Analysis System

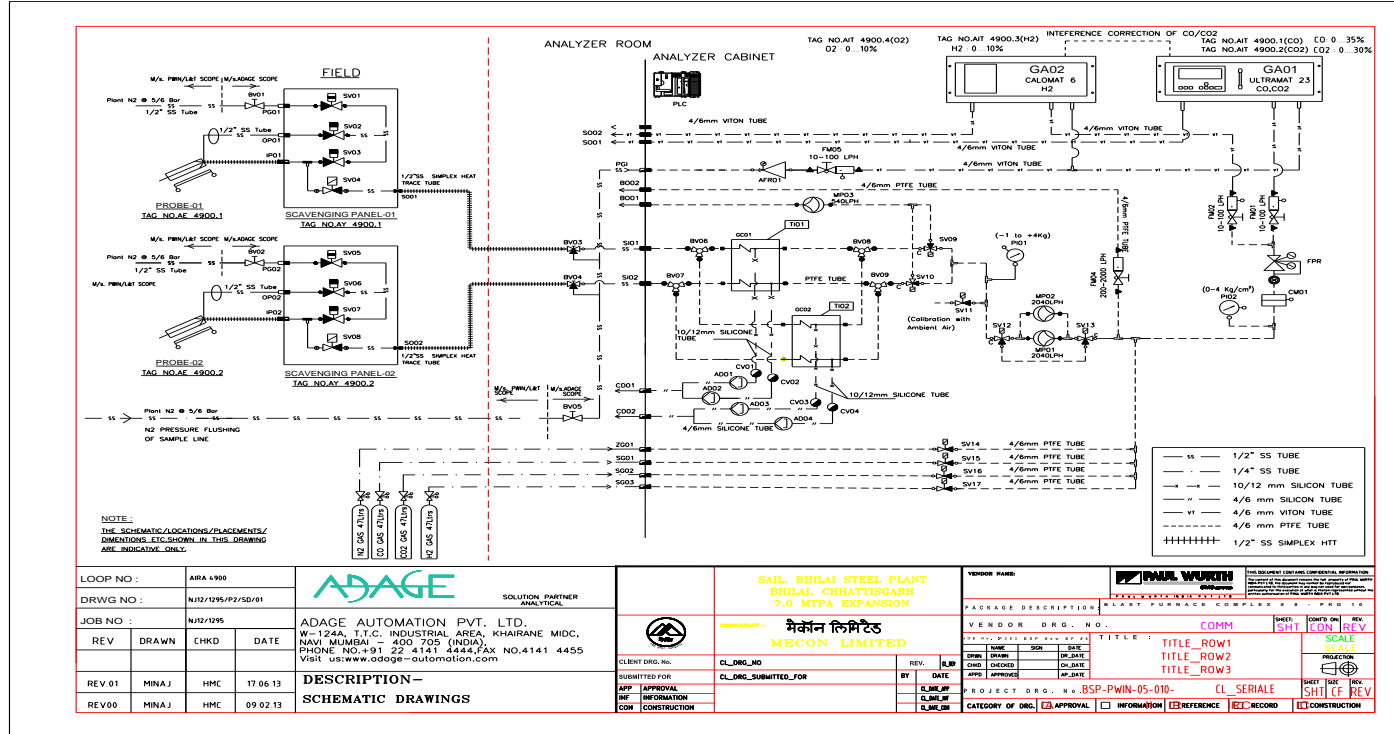

LOOP NO :	ADAGE 4900		
DRWG NO :	NJ12/1295/P2/5D/01		
JOB NO :	NJ12/1295		
REV	DRAWN	CHKD	DATE
REV 01	MINA.J	HMC	17.06.13
REV 00	MINA.J	HMC	09.02.13

ADAGE
SOLUTION PARTNER ANALYTICAL

ADAGE AUTOMATION PVT. LTD.
 W-124A, I.T.C. INDUSTRIAL AREA, KHAIRANE MIDC,
 NAVY MUMBAI - 400 705 (INDIA)
 PHONE NO.+91 22 4141 4444.FAX NO.4141 4455
 Visit us:www.adage-automation.com

DESCRIPTION - SCHEMATIC DRAWINGS

CLIENT ORG. NO.	CL_ORG_NO	REVISIONS
APPROVAL FOR:	CL_ORG_SUBMITTED_FOR	DATE
APP. APPROVAL	DATE	
INF. INFORMATION	DATE	
CON. CONSTRUCTION	DATE	

VENDOR NAME:	PAUL WÜRTH	
PACKAGE DESCRIPTION:	PLAST FURNACE COMPLEX # 1 - P&I 15	
VENDOR DRG. NO.:	COMM	
SHEET NO.	COPIES ON FILE	REV.
TITLE ROW1	SCALE	REV.
TITLE ROW2	SCALE	REV.
TITLE ROW3	SCALE	REV.
PROJECTION		
PROJECT D.R.G. NO.	RSP-PWIN-05-010	CL. SERIAL
CATEGORY OF DRG.	<input checked="" type="checkbox"/> APPROVAL <input type="checkbox"/> INFORMATION <input checked="" type="checkbox"/> REFERENCE <input checked="" type="checkbox"/> RECORD <input checked="" type="checkbox"/> CONSTRUCTION	SHEET NO. / TOTAL

Above Burden Gas Analysis System

Challenges

- There are many points which are to be analysed sequentially.
- The Sample Gas is Raw Sample Gas with High Temperature
- The Dust content is High
- There is High Moisture.
- The Gas is already at elevated pressure.

Above Burden Gas Analysis System

Primary Sampling System

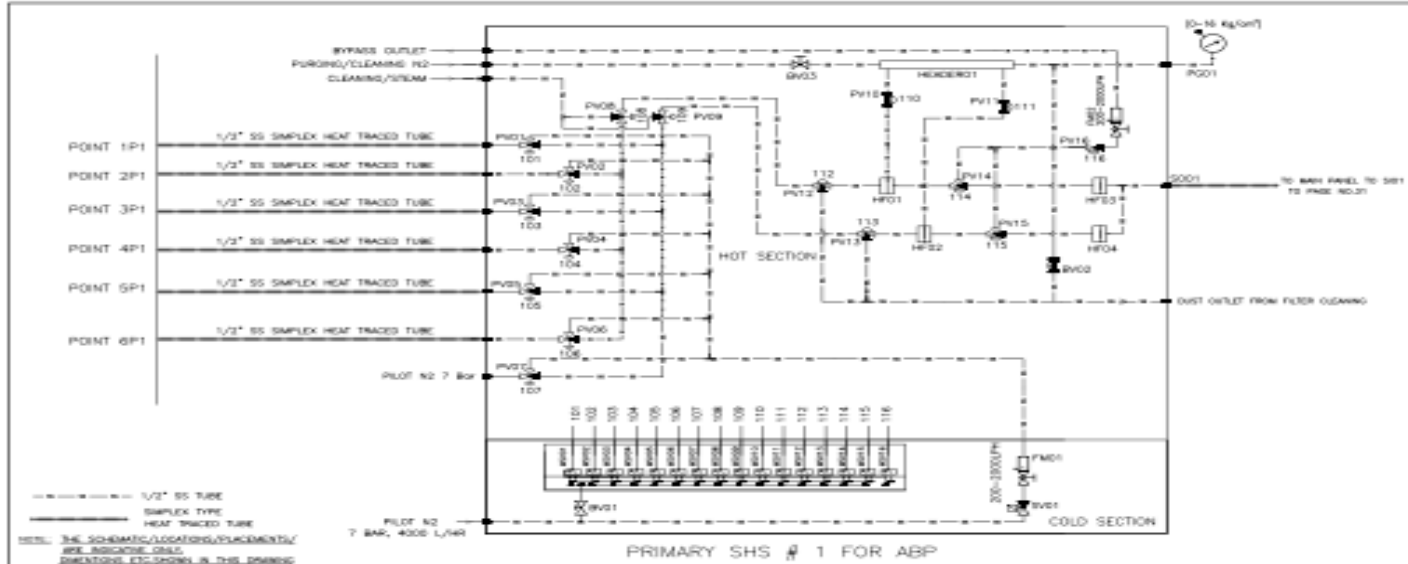

L D O P N O ABA-ESAG-1-3 DRAWG NO: PA12/028/PRD/0/01 J O B N O PA12/028 REV DRAWN CHKD DATE REV00 MVAL HMC 13.09.13				ADAGE SIEMENS Solution Provider ADAGE AUTOMATION PVT. LTD. W-126A, T.S.C. INDUSTRIAL AREA, KANURAME MOO, NAGALAND - 785 125 (INDIA) PHONE NO: +91 32 4181 8449/30; 90 4141 4450 Web: www.adage-automation.com		 REL. SHILPA STEEL PLANT NEELAM CHATTOPADHYAY T.S. NYDA EXPANSION MECON LIMITED		PACKAGE DESCRIPTION: BLAST FURNACE COMPLEX # 0 - PKG 19 VEHICOR DRG. NO.: 58393 42 31 001 PROJECT DRG. No.: BSP-PWM-05-210-01-843-37-DE-03020 LEGEND: <input type="checkbox"/> BUIL <input type="checkbox"/> APPROV <input type="checkbox"/> IMPROV <input type="checkbox"/> REVER <input type="checkbox"/> REOR <input type="checkbox"/> CORRIG	
DESCRIPTION: SCHEMATIC DRAWING				CLIENT DRG. No.: DATE: BY: DATE:		SCALE: DATE: BY: DATE:			

Above Burden Gas Analysis System

Cooler Panel

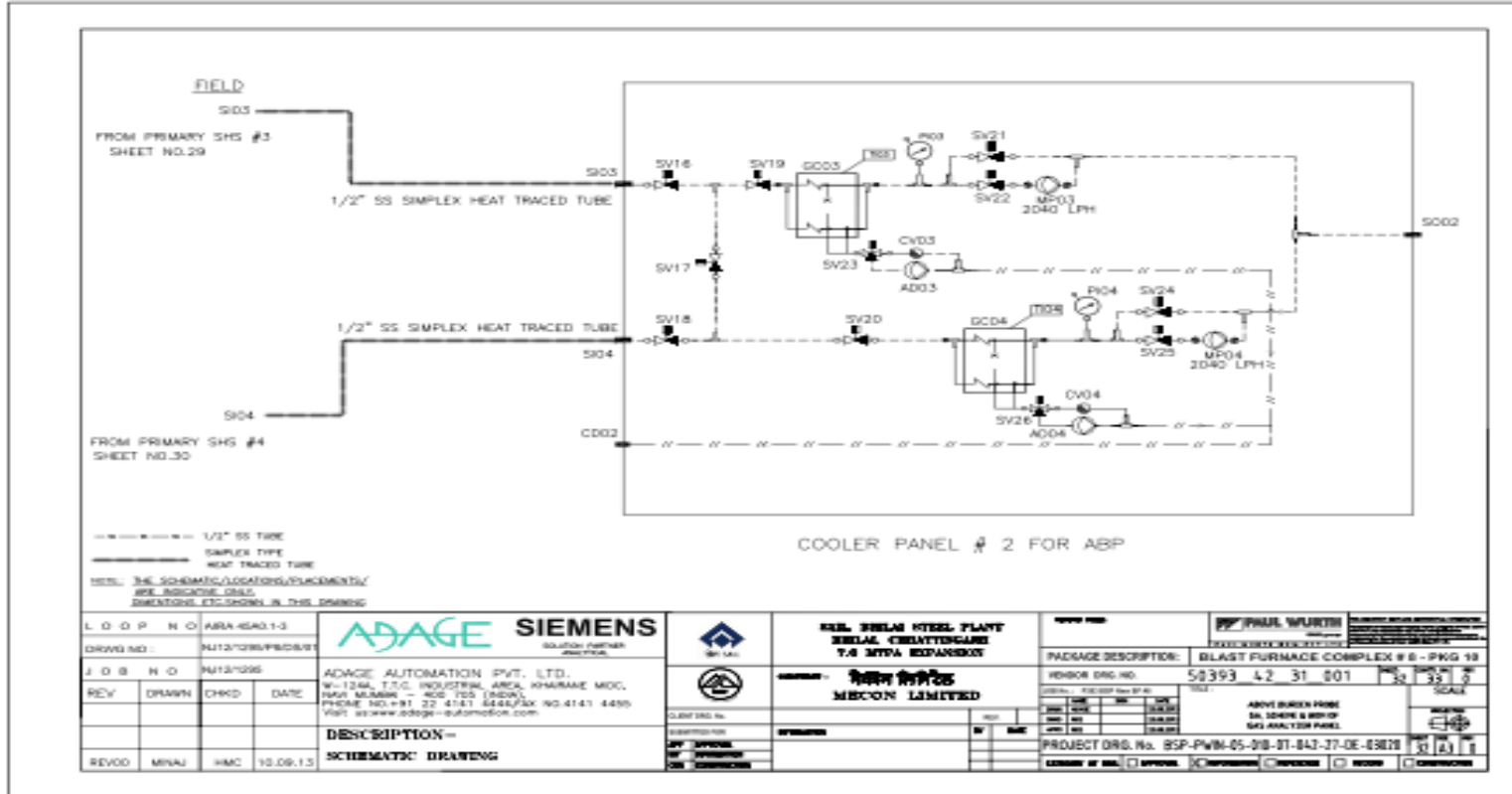

Above Burden Gas Analysis System

Gas Analyser Panel

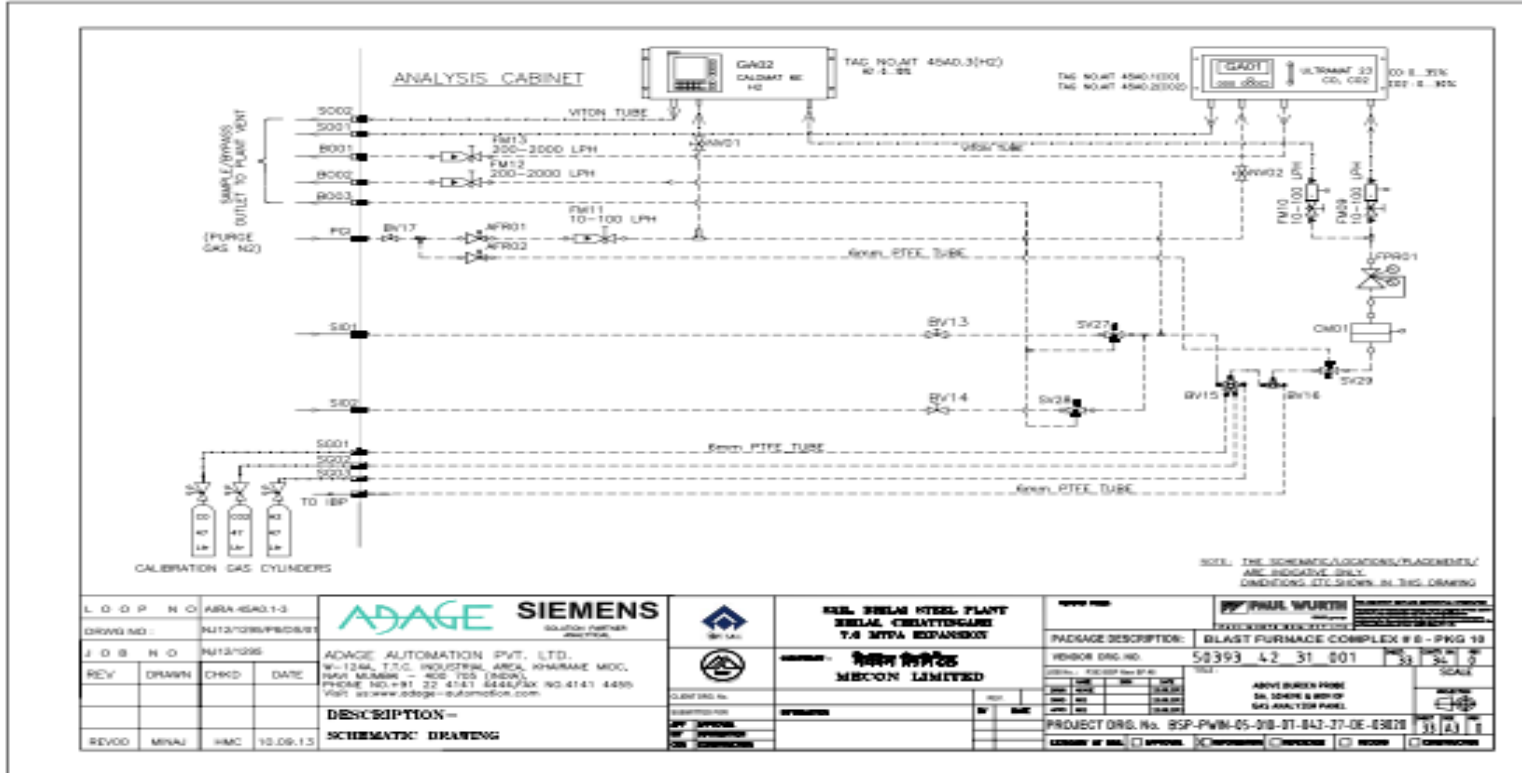

<table border="1"> <tr> <td>L O O P N O</td> <td>ARA-4540.1-3</td> </tr> <tr> <td>DRWG NO :</td> <td>PA12/GNS/P/02/B/E</td> </tr> <tr> <td>J O B N O</td> <td>PA12/1295</td> </tr> <tr> <td>REV</td> <td>DRAWN</td> <td>CHKD</td> <td>DATE</td> </tr> <tr> <td>REV00</td> <td>MNAJ</td> <td>HMC</td> <td>10.09.13</td> </tr> </table>	L O O P N O	ARA-4540.1-3	DRWG NO :	PA12/GNS/P/02/B/E	J O B N O	PA12/1295	REV	DRAWN	CHKD	DATE	REV00	MNAJ	HMC	10.09.13	 ADAGE AUTOMATION PVT. LTD. W-124A, T.T.C. INDUSTRIAL AREA, KHARANE MOO. PUNE MUMBAI - 406 125 (INDIA) PHONE NO.-91 22 4141 8448/FAX NO-4141 4455 Web: www.adage-automation.com	 MBCON LIMITED	RAJ. STEEL ROLL PLANT BELGA CHATTISGARH 7.6 MTPA EXPANSION भारत स्टील इन्डिया लिमिटेड	PACKAGE DESCRIPTION: GAS ANALYSER PANEL REVISION NO.: 50393 42 31 001 PROJECT DRG. No.: RSP-PVN-05-018-37-043-27-0E-03020
L O O P N O	ARA-4540.1-3																	
DRWG NO :	PA12/GNS/P/02/B/E																	
J O B N O	PA12/1295																	
REV	DRAWN	CHKD	DATE															
REV00	MNAJ	HMC	10.09.13															

O2 Measurement in Cold Blast

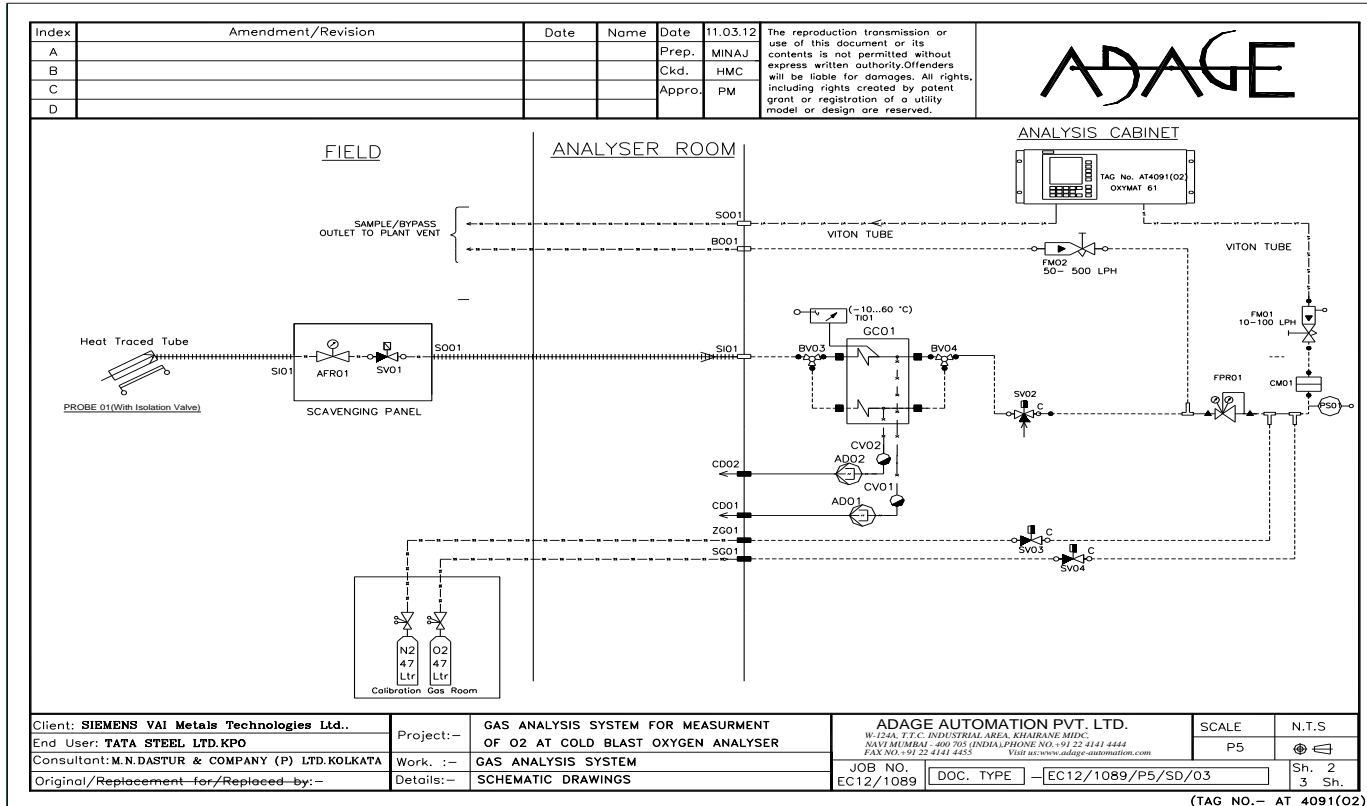

Stove Waste Gas Analysis

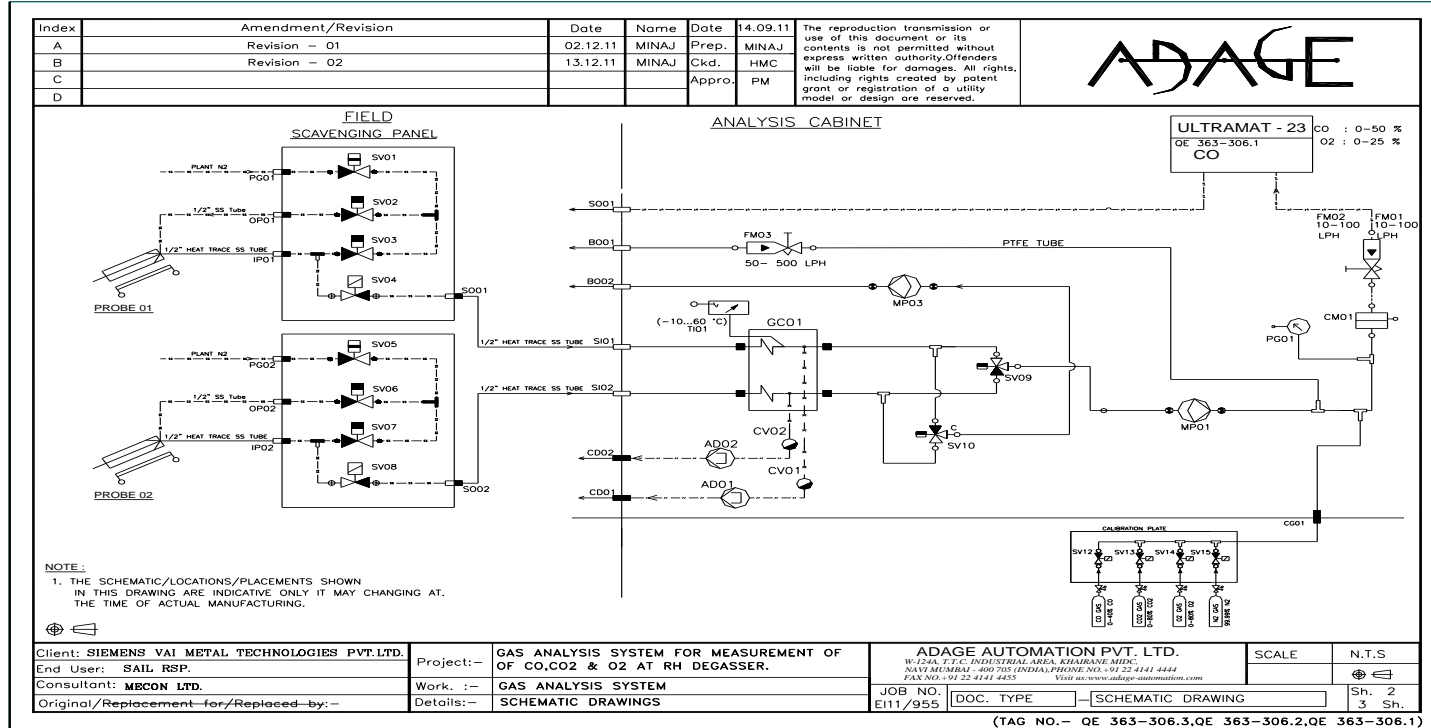

Application – Measurement of O2 Gas Holder

LD Gas is stored in the Gas Holder- The Gas is rich in Calorific Value and with a little extra O2 the Gas can become an explosive mixture.

- ***The aim is to detect the presence of O2 > 2 % at the fastest possible time.***
- To take corrective action to prevent the O2 from reaching the Gas Holder
- To have a System that is reliable and has the least maintenance.

- **Introduction of Laser Analyzer SITRANS SL with response time <2secs**
- Laser Sitrans SL has an internal reference Cell which is checked 24 times per second to give an correct measurement of O2.
- The System is Field mounted there is no need for Analyser Room.
- Spares requirement is minimum.



Advantages of Laser Analyser

LIFE TIME CALIBRATION FREE

NO EFFECT OF HIGH DUST

NO CROSS INTERFERENCE

NO EFFECT OF HIGH MOISTURE

SUPER FAST

NO RANGE LIMITATIONS

NO EFFECT OF VIBRATION

HIGH SENSITIVITY

HIGH SELECTIVITY

NO CONSUMABLES

SITRANS SL

- SITRANS SL is an all-in-one transmitter-like laser gas analyzer.
- SITRANS SL is a non fiber optic-based system.

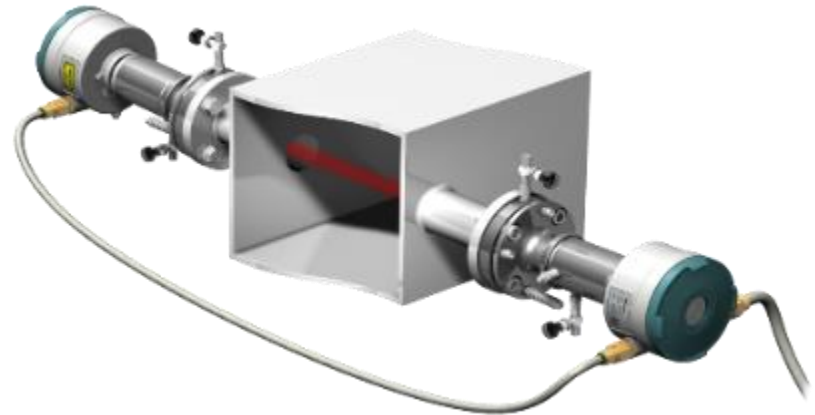

Standardized design also for hazardous zones

Physikalisch-Technische Bundesanstalt
Braunschweig und Berlin



EG-Baumusterprüfbescheinigung

- (1) **EG-Baumusterprüfbescheinigung**
- (2) Geräte und Schutzsysteme zur bestimmungsgemäßen Verwendung in explosionsgefährdeten Bereichen - **Richtlinie 94/9/EG**
- (3) EG-Baumusterprüfbescheinigungsnummer
PTB 08 ATEX 1008 X
- (4) Gerät: Kontinuierlicher Gasanalysator SITRANS SL
- (5) Hersteller: Siemens AG
- (6) Anschrift: 76181 Karlsruhe, Deutschland
- (7) Die Bauart dieses Gerätes sowie die verschiedenen zulässigen Ausführungen sind in der Anlage und den darin aufgeführten Unterlagen zu dieser Baumusterprüfbescheinigung festgelegt.
- (8) Die Physikalisch-Technische Bundesanstalt bescheinigt als benannte Stelle Nr. 0102 nach Artikel 9 der Richtlinie des Rates der Europäischen Gemeinschaften vom 23. März 1994 (94/9/EG) die Erfüllung der grundlegenden Sicherheits- und Gesundheitsanforderungen für die Konzeption und den Bau von Geräten und Schutzsystemen zur bestimmungsgemäßen Verwendung in explosionsgefährdeten Bereichen gemäß Anhang II der Richtlinie.
Die Ergebnisse der Prüfung sind in dem vertraulichen Prüfbericht PTB Ex 08-17 111 festgehalten.
- (9) Die grundlegenden Sicherheits- und Gesundheitsanforderungen werden erfüllt durch Übereinstimmung mit

EN 60079-0:2006	EN 60079-1:2004	EN 60079-7:2007
EN 61241-0:2006	EN 61241-1:2004	EN 60079-28:2007
- (10) Falls das Zeichen „X“ hinter der Bescheinigungsnummer steht, wird auf besondere Bedingungen für die sichere Anwendung des Gerätes in der Anlage zu dieser Bescheinigung hingewiesen.
- (11) Diese EG-Baumusterprüfbescheinigung bezieht sich nur auf Konzeption und Prüfung des festgelegten Gerätes gemäß Richtlinie 94/9/EG. Weitere Anforderungen dieser Richtlinie gelten für die Herstellung und das Inverkehrbringen dieses Gerätes. Diese Anforderungen werden nicht durch diese Bescheinigung abgedeckt.
- (12) Die Kennzeichnung des Gerätes muß die folgenden Angaben enthalten:

II 2 G Ex de IIC T6
 II 2 D Ex tD A21 IP 65 T85 °C



System overview

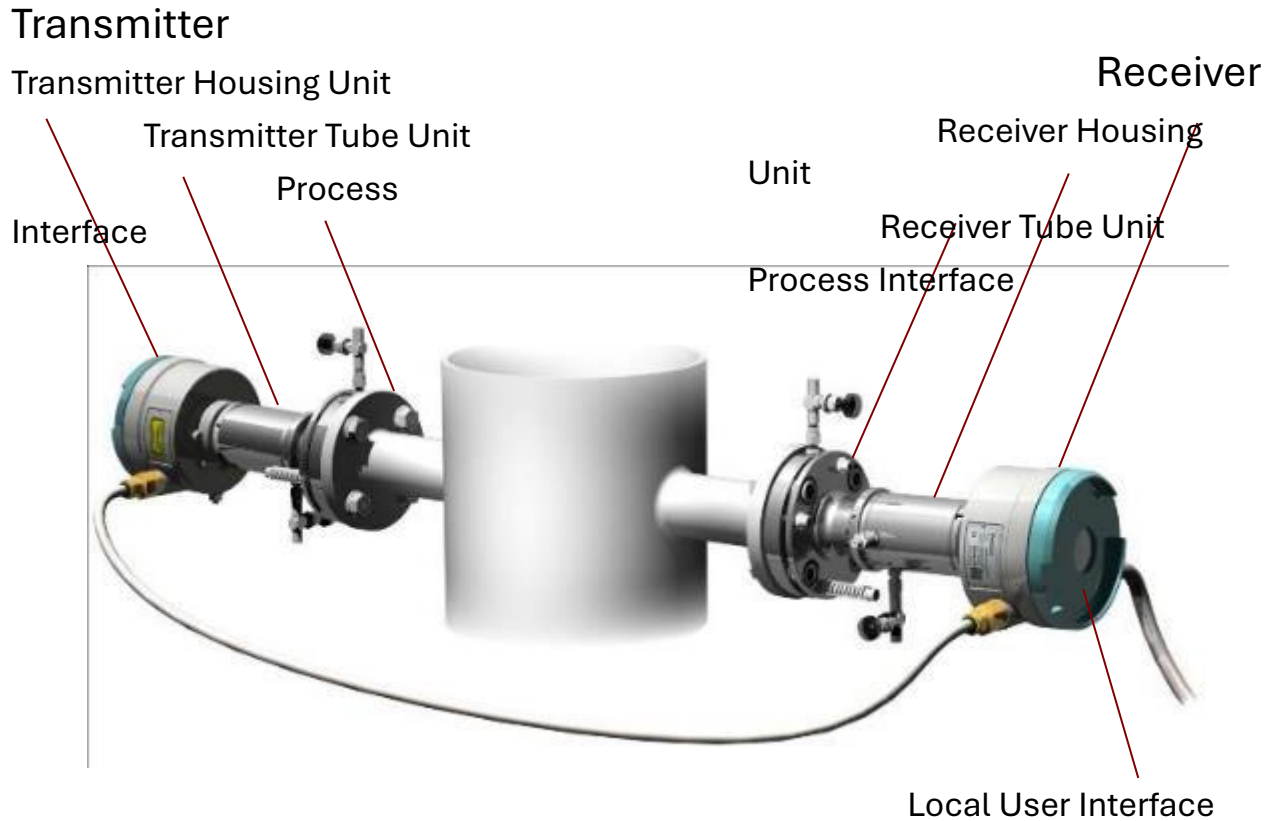

Functionality of the Four Analyzer Modules

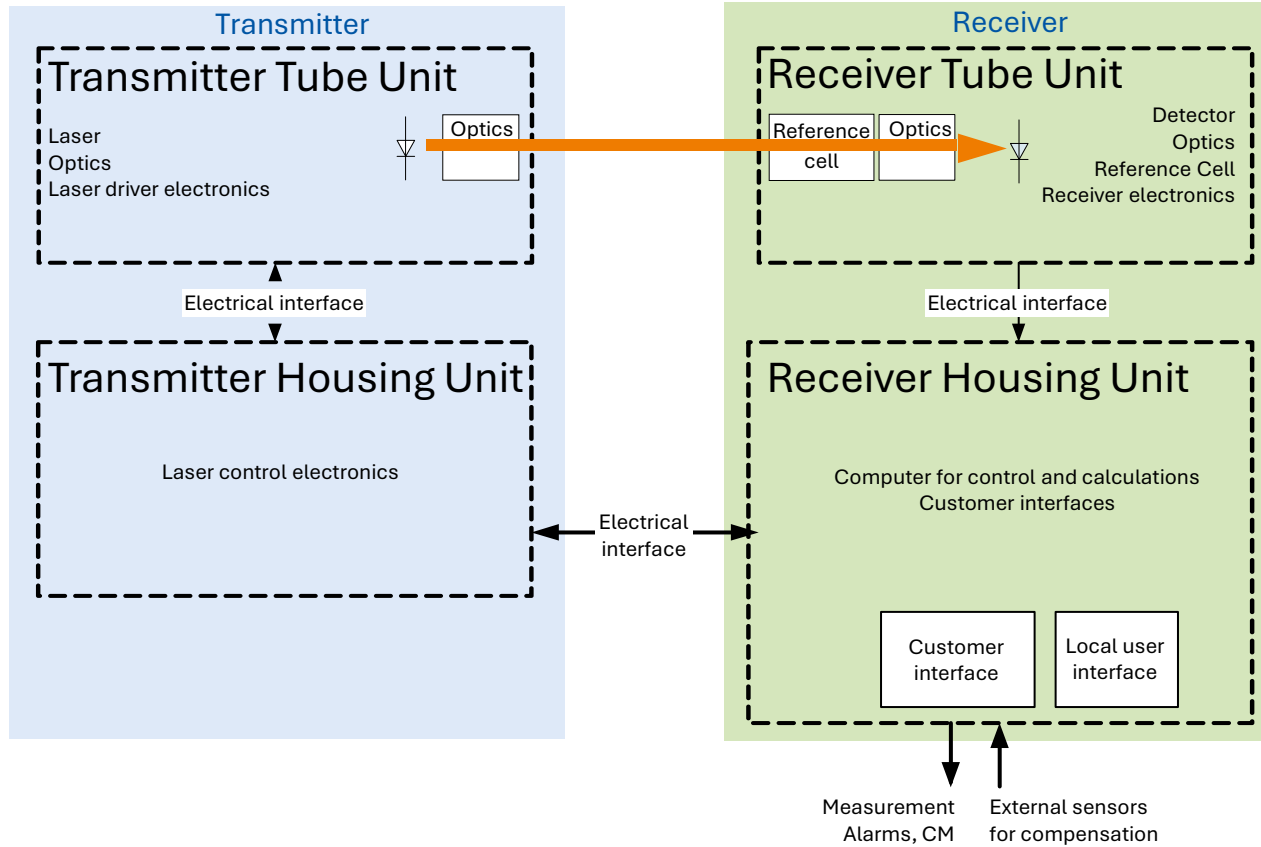

Some Technical Highlights

- **Built-in reference cell (!)**
 - ⇒ **Stable instrument operation**
- **Single line absorption technology using wavelength modulation**
 - ⇒ **High sensitivity**
 - ⇒ **Immunity to interferences**
- **Curve fit and normalization**
 - ⇒ **Accurate measurements in true process conditions**
 - ⇒ **Less matrix effects, higher instrument flexibility**
- **Optical interference reduction**
 - ⇒ **Lower detection limits and less drift**
- **ATEX version available as standard (EEx-d for zone I and II)**
 - ⇒ **No additional external pressure control like for EEx-p required**

Laser Locking with Built-in Reference Channel

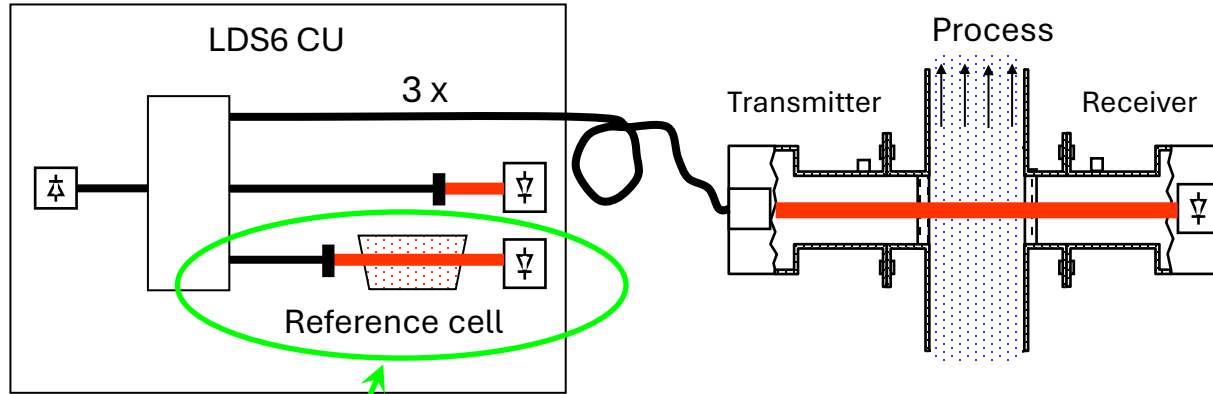

Laser frequency locking is realized with a separate reference channel

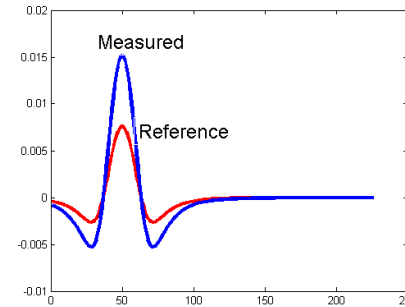

SITRANS SL: Built-in Reference Cell filled with Isotope O18

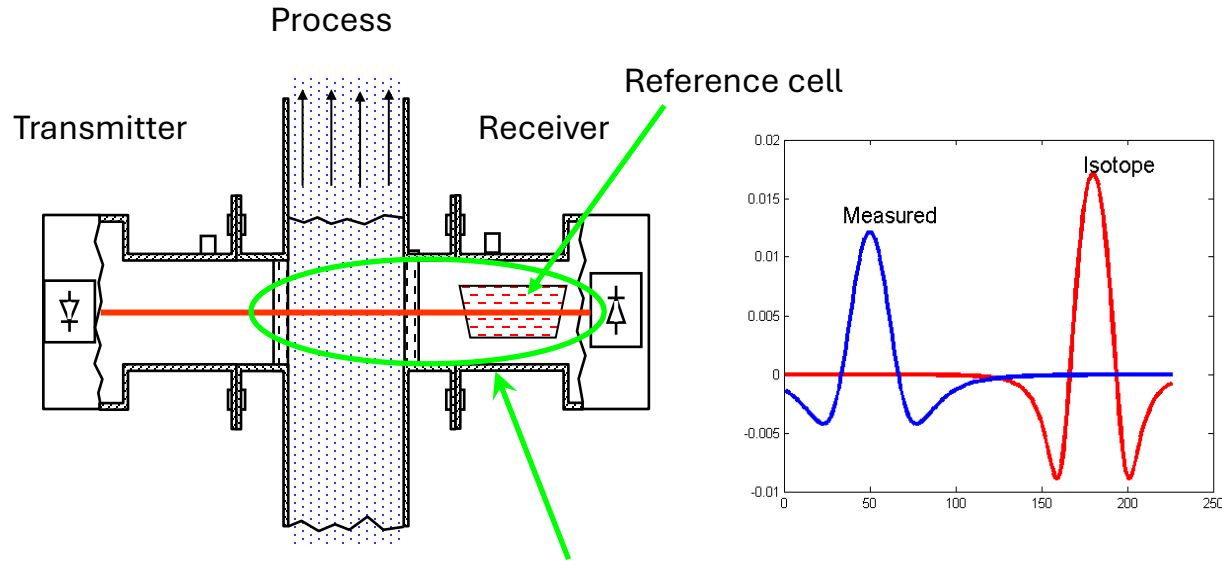

Built-in reference cell with non-interfering gas, here: $^{18}\text{O}_2$

- ➔ Higher stability of the measurement.
- ➔ Locking signal is always available, no signal losses.

Laser Locking with Built-in O18 Isotope Cell : Setting a new Technology Benchmark!

Benefits of the O18 isotope cell solution:

- Better instrument performance
- Less frequent recalibrations
- Present in every analyzer, not just as an option
- A life-time valid instrument calibration.

Better Minimum Detection Limit and Accuracy

- Optical interferences occur when light travels through optical interfaces.
 - These interferences lead to a higher background and worse detection limits.
- ⇒ SITRANS SL reduces interferences via special opto-mechanical design and a vibrating laser holder.

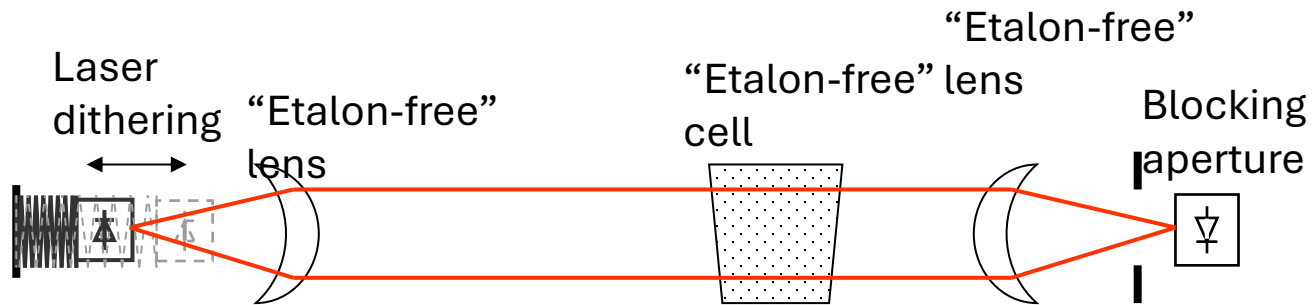

SITRANS SL: EEx-d design

(explosion protection by encapsulation)

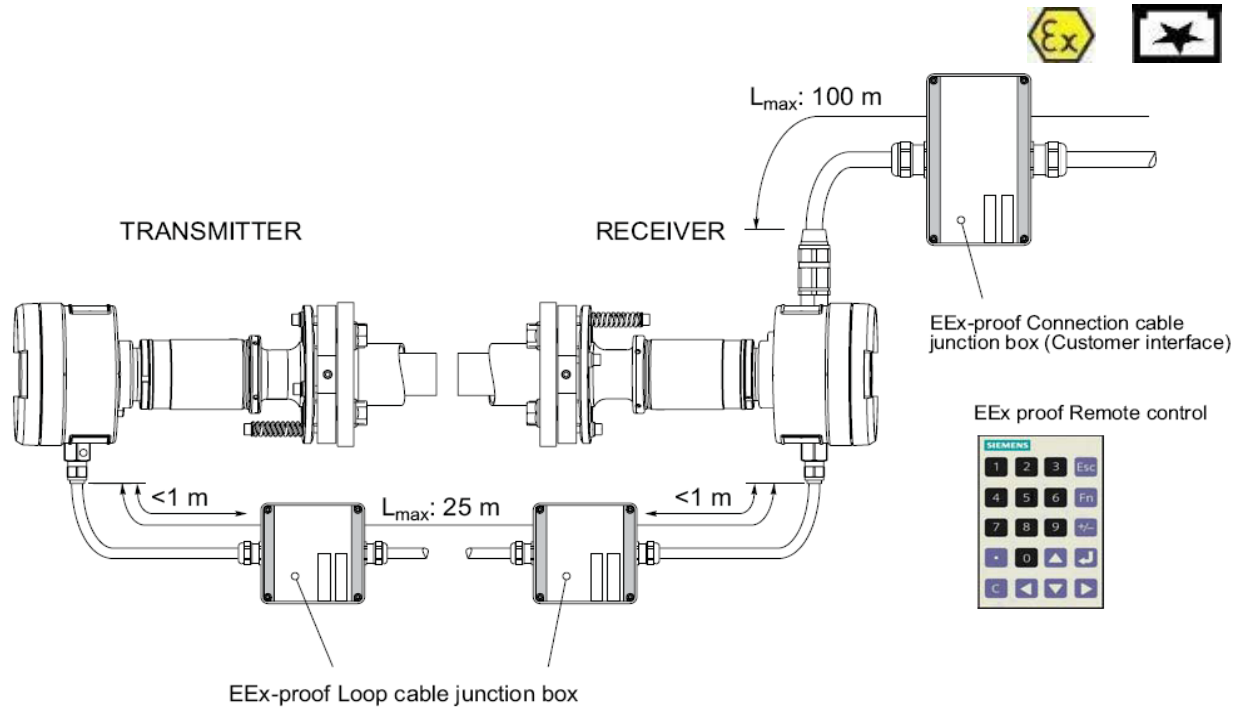

Applications

- **Steel plants**
 - Converters
 - Gas Holder
 - Coke gas
- **Combustion control for boilers**
- **Combustion control for MWIs**
- **Chemical Applications:**
 - Safety monitoring
 - Process control

Setting a new TDLS Technology Benchmark:

- **O18 reference cell**
 - ⇒ non-interfering reference gas
 - ⇒ Less demand for verification (minimum for 1 year!)
 - ⇒ Stability and Availability
- **EEx-d version as standard, without need of additional EEx-p pressure control units**
- **Wireless parameterization in EEx-zones**
- **Profibus DP communication as an option**

Installation Photographes



Application – Measurement of O₂ Gas Holder

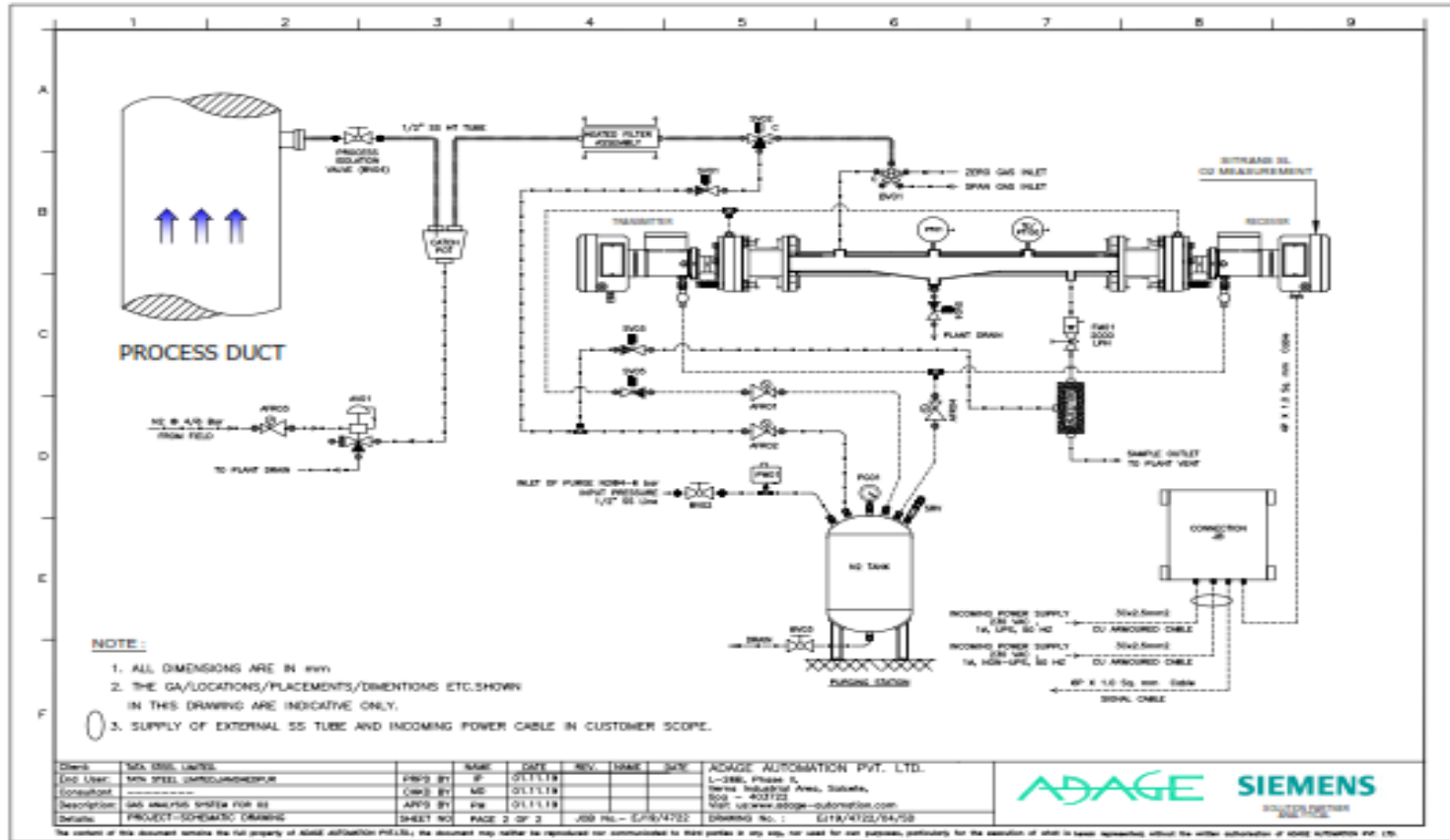

System Installation Photographs



**Worlds Most installed
NDIR Analyzer**



Ultramat 23

ULTRAMAT 23 - Multi-component Gas Analyzer

- **Central Electronics concept with Sensor Module**
 - Saves costs and space
 - One analyzer, one gas path, less maintenance
- **AUTOCAL with ambient air due to inbuilt Gas Filled detector (TUV Certified)**
 - No calibration gases and valves necessary
- **High selectivity by using multi-layer detectors**
 - Less interference (e.g. with water)
- **Sample cell is easy to clean**
 - Cost-saving by reusing the sample cell after cleaning
- **Menu driven operation in plain text**
 - Easy to operate, without manual
- **Freely programmable measuring ranges and output signals**
- **Service information and logbook**
 - Preventive maintenance, support for commissioning, cost-saving
- **Open interface architecture (RS 485/232, PROFIBUS, SIPROM GA)**
 - Improved and easy system integration, remote control and monitoring



ULTRAMAT 23 - Multi-component Gas Analyzer

- Highly selective measurement of up to 3 IR-active components
- Paramagnetic Sensor Dumbbell for oxygen measurement
- 19" rack version
- Freely programmable measuring ranges and output signals
- Unparalleled cost/performance ratio



Gas Component	Smallest Measuring Range	
CO	0-50 ppm	0-150 mg/m ³
CO ₂	0-50 ppm	
NO	0-100 ppm	0-100 mg/m ³
SO ₂	0-150 ppm	0-400 mg/m ³
CH ₄	0-500 ppm	

ULTRAMAT 23 - Multi-component Gas Analyzer



- Large, easy to read display
- Versatile display in all measuring units: ppm, %, mg/m³
- Information about pre-warnings, faults, limits, maintenance, pump, coding
- Logbook



- Self explanatory plain text menus
- Pushbutton operation
- Access to all internal functions and operating parameters
- Code protected operating levels

Measurements in the infrared wavelength range: 2-9 μm

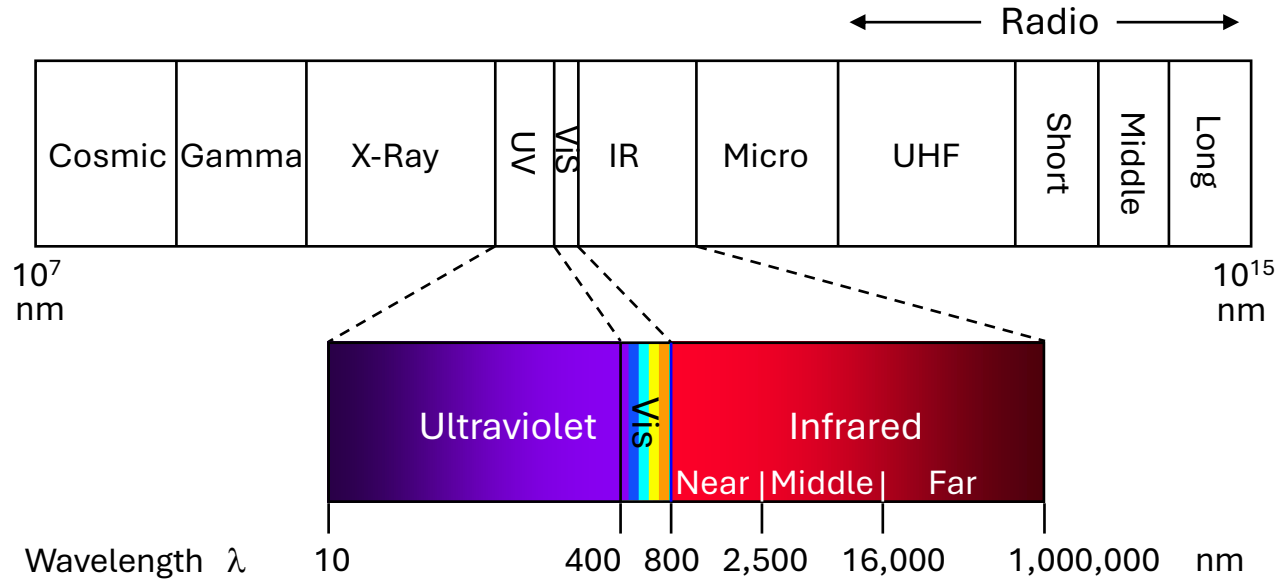

Ultramat 23 - The unique AUTOCAL Principle

During the AUTOCAL procedure, the sample cell is purged with air. This causes the highest detector signal U_0 (no pre-absorption).

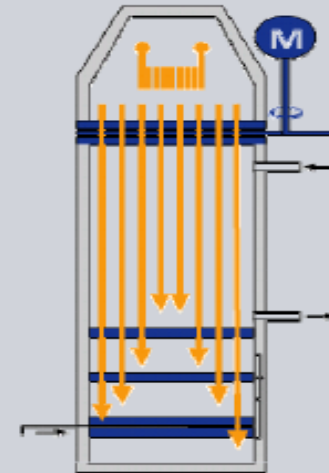
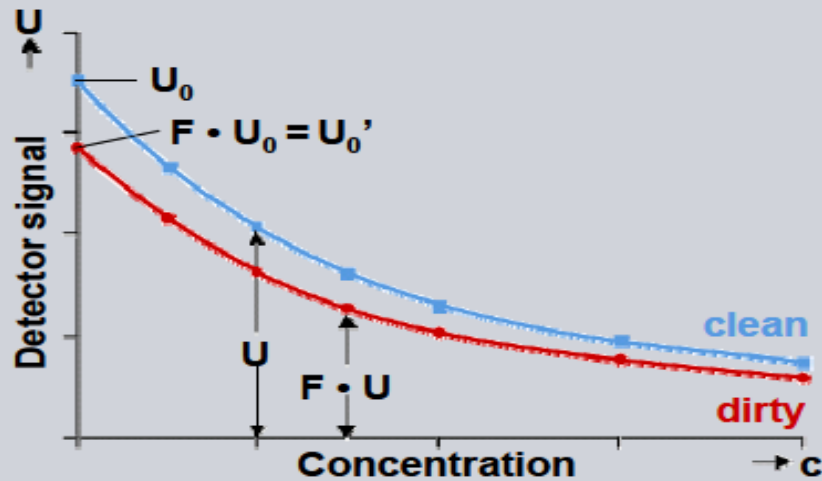

- Measuring very small alternating flows
- No membrane detector
→ no ‘microphony effect’
- No moving parts → not subject to wear

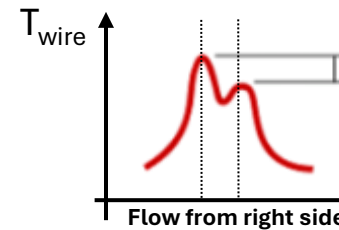
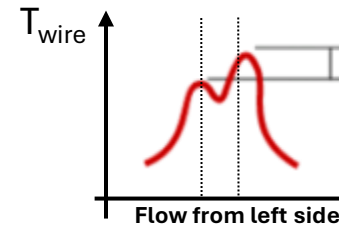
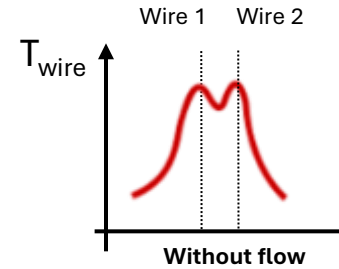
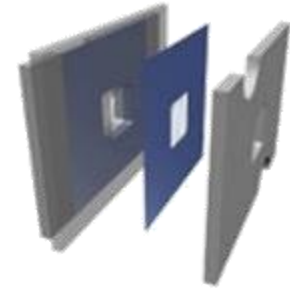
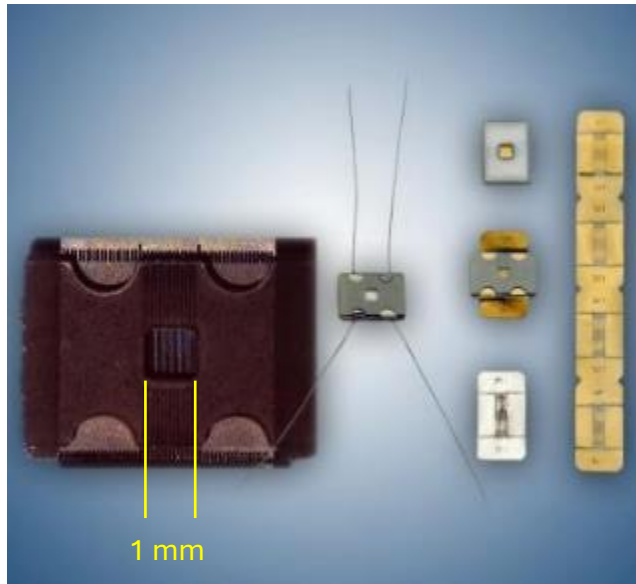

The Oxygen Measurement

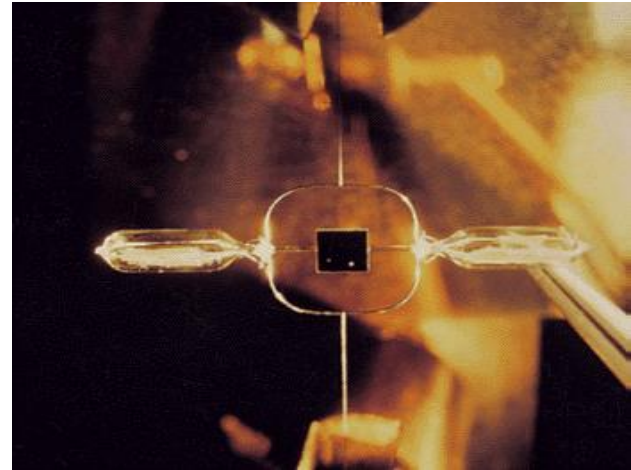
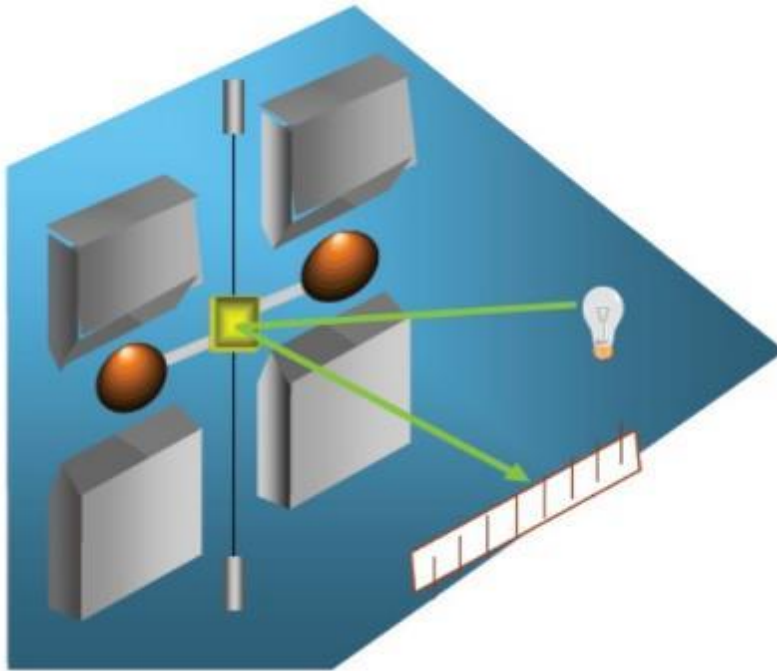

Gas Analytical Experts

UNION CWD-2005

THE CALORIMETER



UNION Instruments: Direct Calorimeter CWD2005

- Direct Net Heating Value Combustion Calorimeter with continuous on-line measurement
- Output signals:
 - Wobbe-Index (real time measurement)
 - Specific Gravity (real time measurement)
 - Calorific value (real time measurement) calculated from the values below
- Different version are available to meet the specific application requirements



Calorific Values Basics

Combustion:

An exothermic reaction between a fuel and oxygen accompanied by the production of energy (heat)

$$\text{Thermal Load } P = \text{heating value} \times \text{gas flow}$$

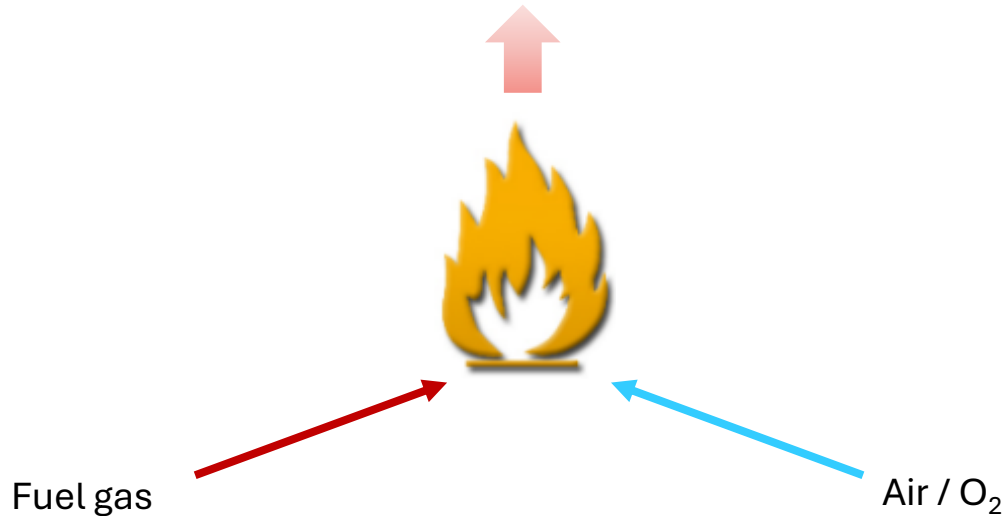

Calorific Values Basics

- **Combustion:**
An exothermic reaction between a fuel and oxygen accompanied by the production of energy (heat)

- Calorific value (CV) represents the amount of released heat/energy
 - Gross CV* (H_S): With condensation of the water vapour (with heat of condensation)

 - Net CV* (H_I): Without condensation of the water vapour (without heat of condensation)

 - Gross CV is higher than Net CV (e.g. natural gas approx. 10 %)

*Gross CV: superior, upper, gross calorific value

*Net CV: inferior, lower, net calorific value, heating value

Calorific Values Basics

- **Wobbe-Index:**
Indicator for the interchangeability of combustion gases in burners
- Corrected Calorific Value
- Relation between specific gravity S.G. and calorific value H

$$WI = \frac{H}{\sqrt{dv}}$$

Control of the amount of energy introduced to the burner.

UNION Instruments

Calorific Values Basics

- **Combustion Power:**

The Combustion Power is the product of volume flow and Heating Value

$$P = V \cdot CV = K \cdot \frac{\sqrt{dp}}{\sqrt{dv}} \cdot CV = K \cdot \sqrt{dp} \cdot WI$$

Direct Calorimeter CWD2005

1. Gas inlet controlled by solenoid valves

- Input pressure: 12" - 16" H₂O
- Up to 5 gas inputs:
Up to 2 process gas and
2 calibration gas inlets,
Optional:
1 inlet for carrier gas or
1 inlet for test gas

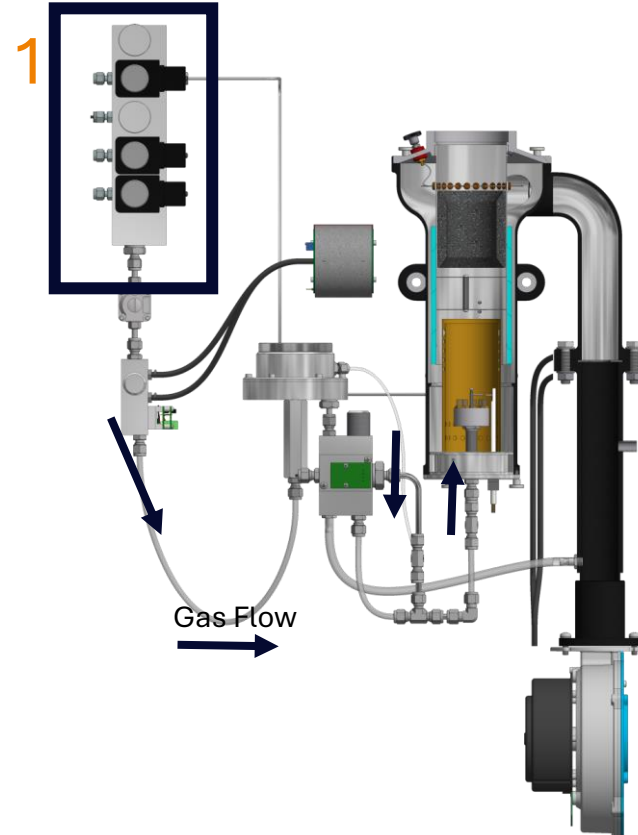

Direct Calorimeter CWD2005

5. Precise pressure regulator and specific sized gas orifices regulating gas flow to burner
6. The gas is burned with partial premixed flame
7. Flue gases are mixed with air

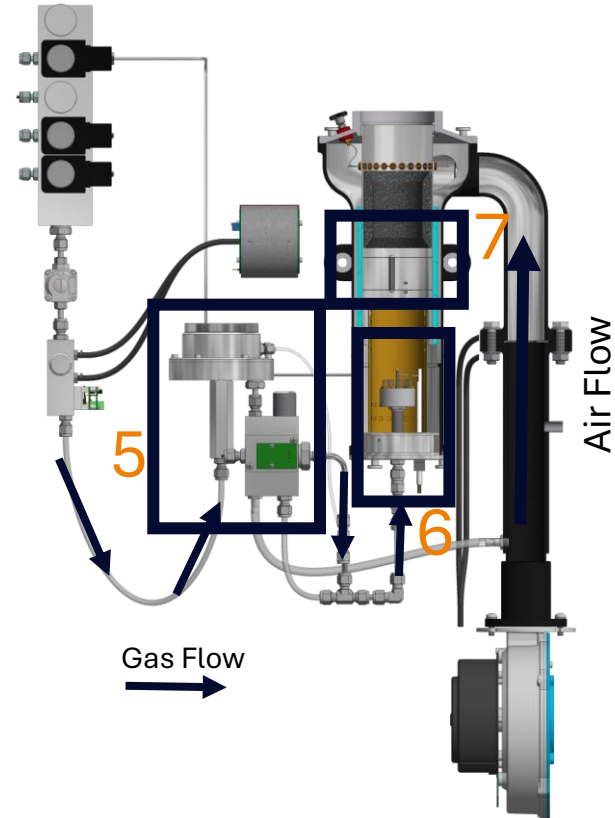
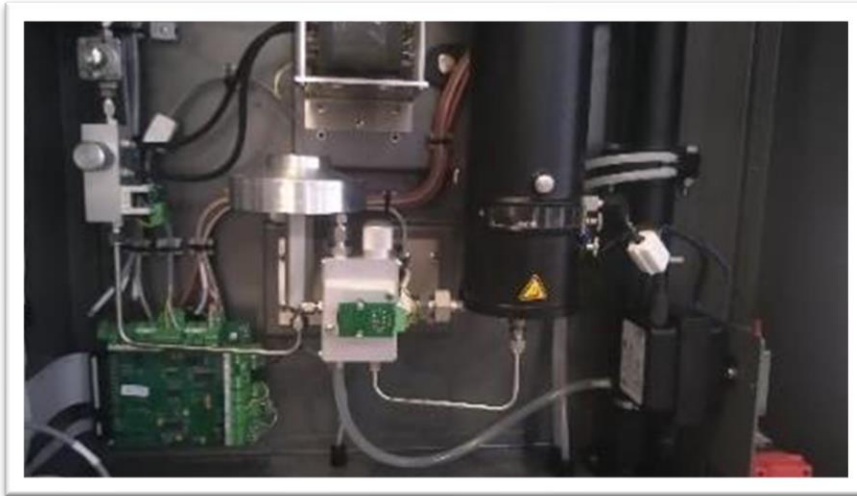

UNION Instruments

Direct Calorimeter CWD2005

8. Temperature rise is measured with thermopile

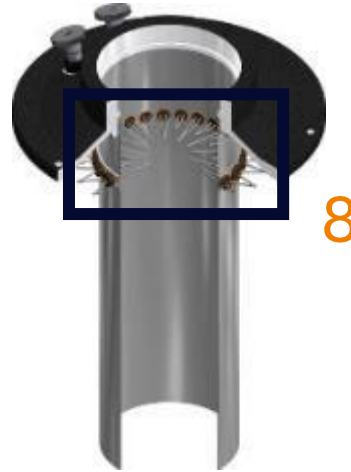
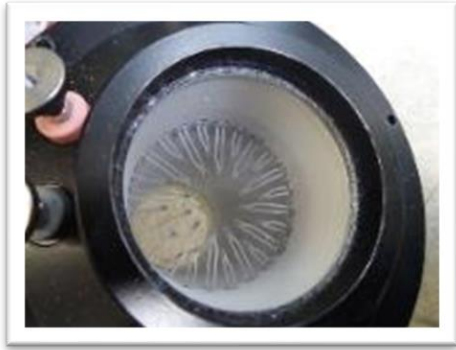

Cross-sectional view showing
Thermopile

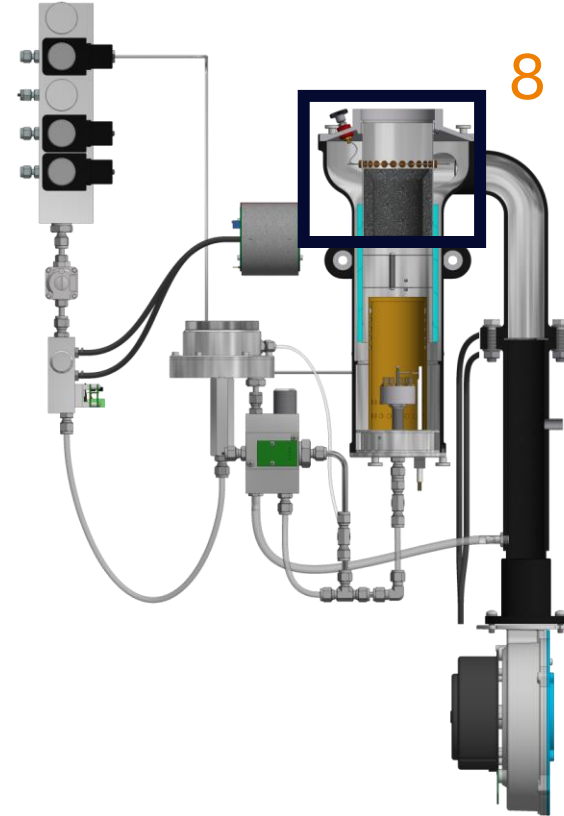

Direct Calorimeter CWD2005 Basic principles

7. Temperature rise ΔT (mV)
~ generated heat rate
~ Wobbe Index value

$$W_i = W_{i,Calibration_Gas} \cdot \frac{\Delta T}{\Delta T_{Calibration_Gas}}$$

8. Calorific value is calculated with specific gravity measurement

$$CV_i = W_i \cdot \sqrt{spec.gravity}$$

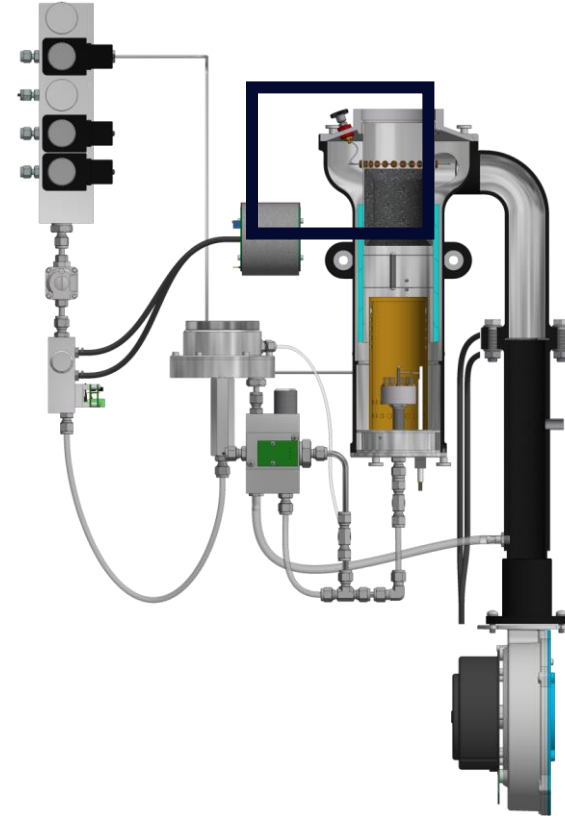

Direct Calorimeter CWD2005 Basic principles



Direct Calorimeter CWD2005

Features and Benefits

- Up to **3 measuring ranges** are possible
 - High accuracy of measured values in lower ranges
- **All combustible components** of a process or vent gas are captured and combusted providing a Direct Measurement.
 - No additional correlations and calibration gases required!
- Complete combustion → **Zero Emissions**
- Clearly defined **Zero Point** provided by **thermopile detection** method.
- No open flame

Direct Calorimeter CWD2005

Features and Benefits

High system availability and low maintenance needs

- No large high temperature oven needed. Heat source cools down in seconds.
 - Just one small heat source: An ignition electrode that's only 1 mm diameter.
- Corrosion resistant wetted parts
- Low pressure system and high dilution air purge
 - No Acid dewpoint or flue gas condensation
- Low maintenance with minimal cleaning required for products of combustion.
- No sample pump required

Valuable Gases Due To Energy Content

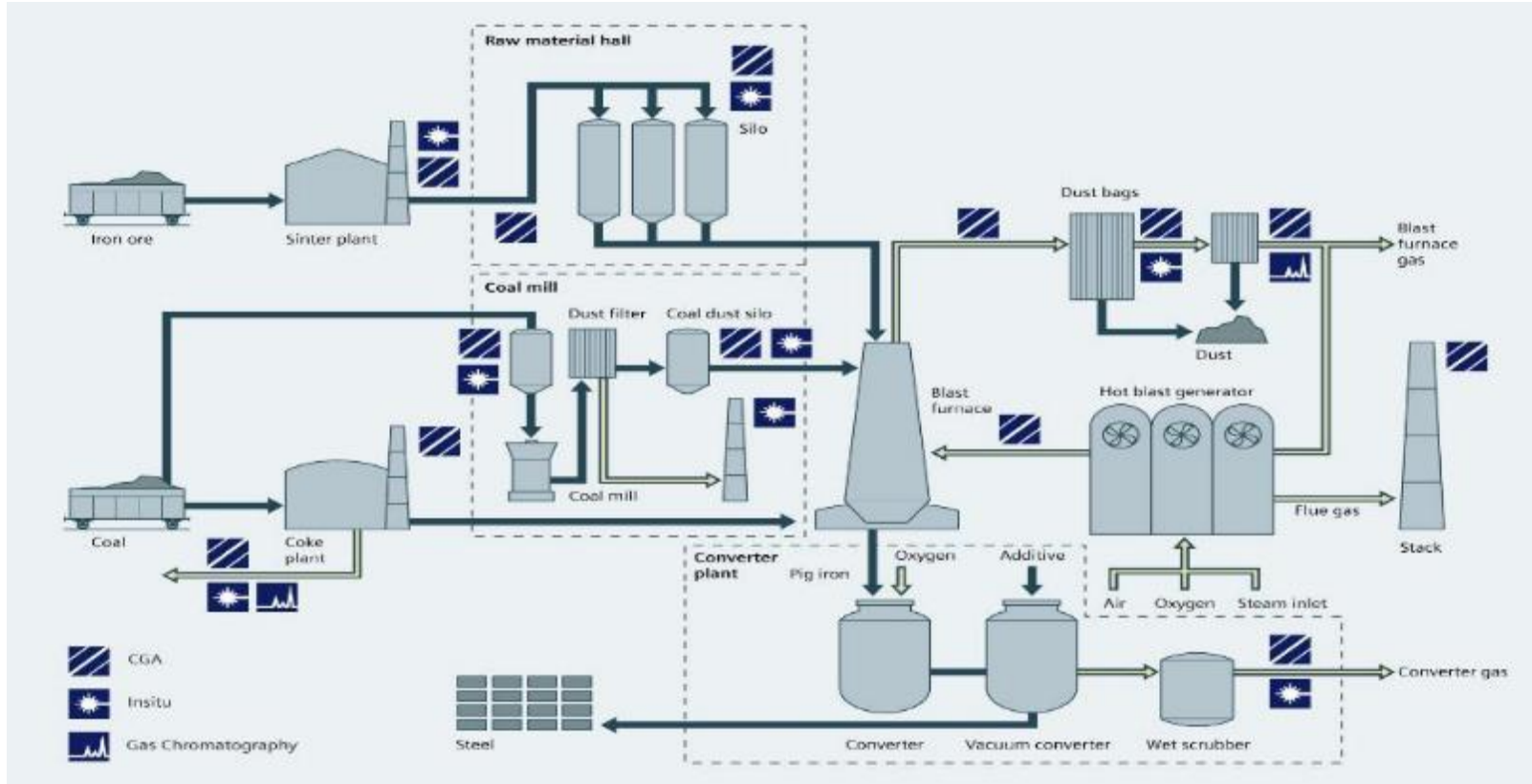

Challenge : Mix the gases to required CV

BFG Blast Furnace Gas		COG Coke Oven Gas		LDG Converter Gas	
CO ₂	17 - 19 V%	CO ₂	2.8 - 3.2 V%	CO ₂	13 - 15 V%
O ₂	0.4 - 0.8 V%	O ₂	0.8 - 1.0 V%	O ₂	1.0 - 2.0 V%
HC unsat.	0	HC unsat.	2.5 - 3.4 V%	HC unsat.	0
CO	21- 25 V%	CO	8.8 - 9.0 V%	CO	50- 70 V%
H ₂	3.6 - 6.0 V%	H ₂	53 - 55 V%	H ₂	2.0 - 3.0 V%
CH ₄	0	CH ₄	21 - 23 V%	CH ₄	0
N ₂	Balance	N ₂	Balance	N ₂	Balance
CV	800 - 900 kcal / Nm ³	CV	3800 - 4200 kcal / Nm ³	CV	1700 - 1800 kcal / Nm ³

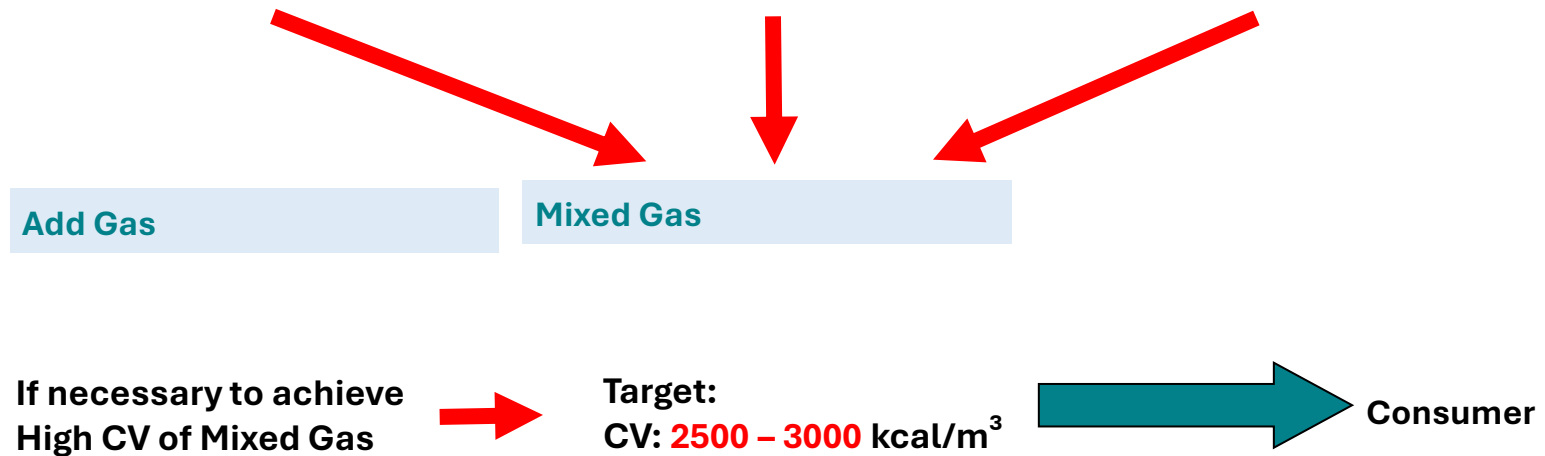

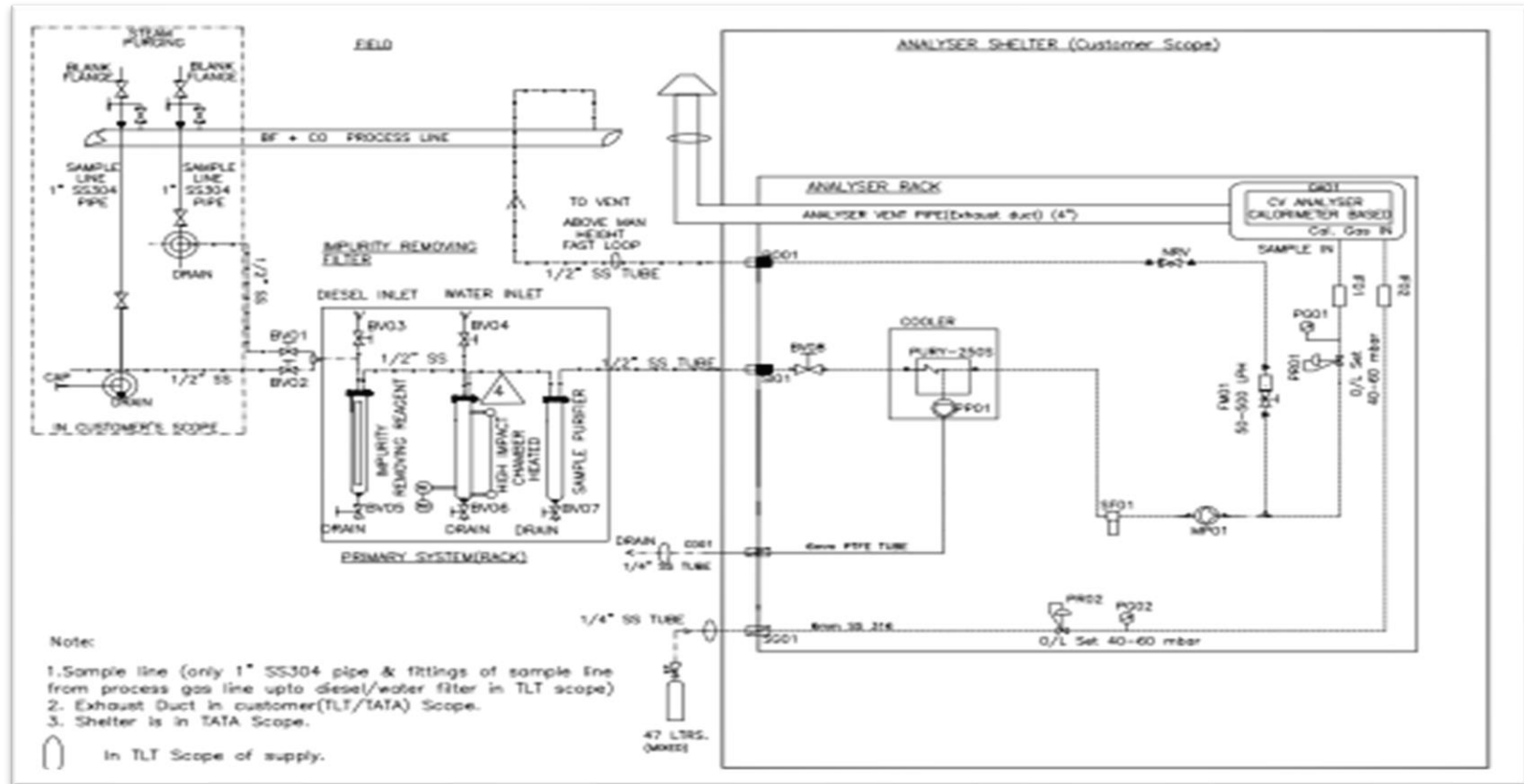

Primary Sampling System



Primary Sampling System

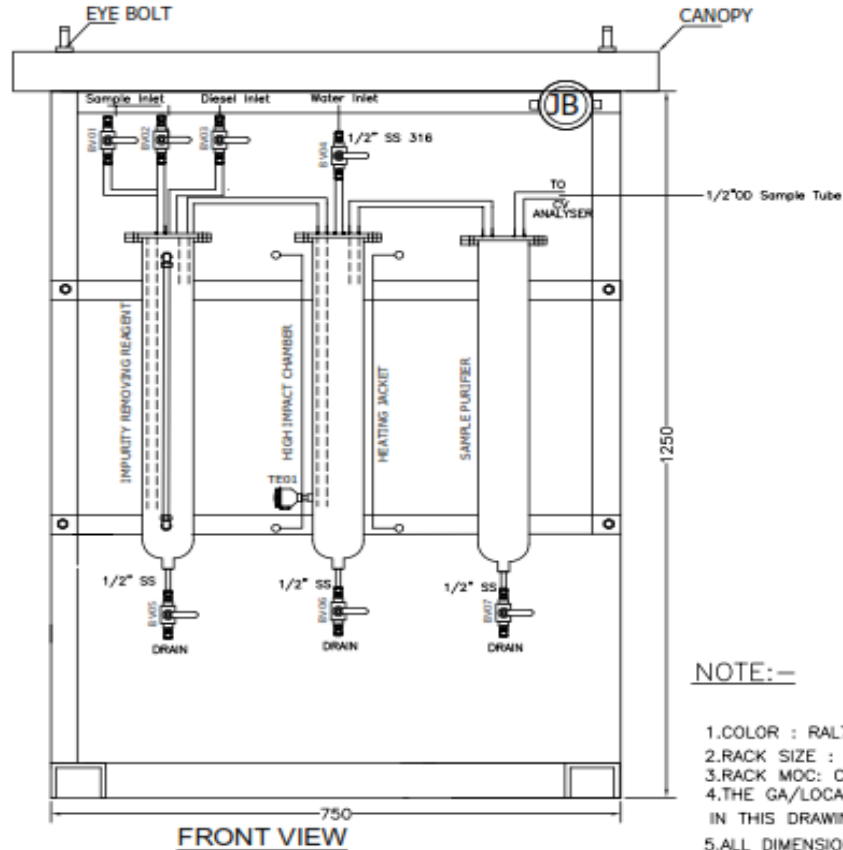

NOTE:—

- 1.COLOR : RAL7035
- 2.RACK SIZE : 1250(H) x 750(W) x 500(D)
- 3.RACK MOC: CRCA ; BUBBLER MOC: SS316
- 4.THE GA/LOCATIONS/PLACEMENTS ETC.SHOWN IN THIS DRAWING ARE INDICATIVE ONLY.
- 5.ALL DIMENSIONS ARE IN MM.

Secondary Sampling System

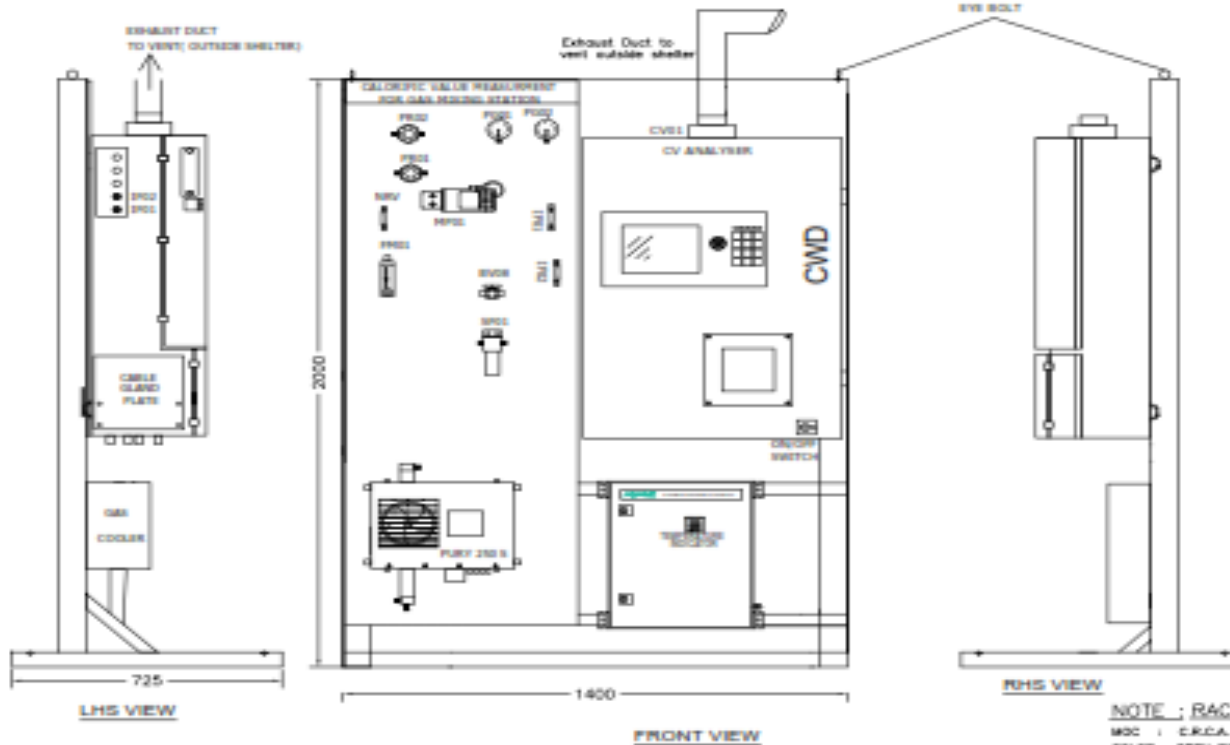

NOTE : RACK
 MFC : C.R.C.A.
 COLOR : GREY POWDER COATING.
 RACK SIZE : 2000(D) x 1400(W) x 725(D)
 W/6 LIFTING EYE BOLT TO BE FIXED ON TOP FOR LIFTING.
 MAKE - ADAGE.
 THE GA/LOCATIONS/PLACEMENTS/DIMENSIONS ETC.SHOWN
 IN THIS DRAWING ARE INDICATIVE ONLY.
 EXHAUST DUCT IN CUSTOMER SCOPE.

Schematic for LD Gas & BF Gas

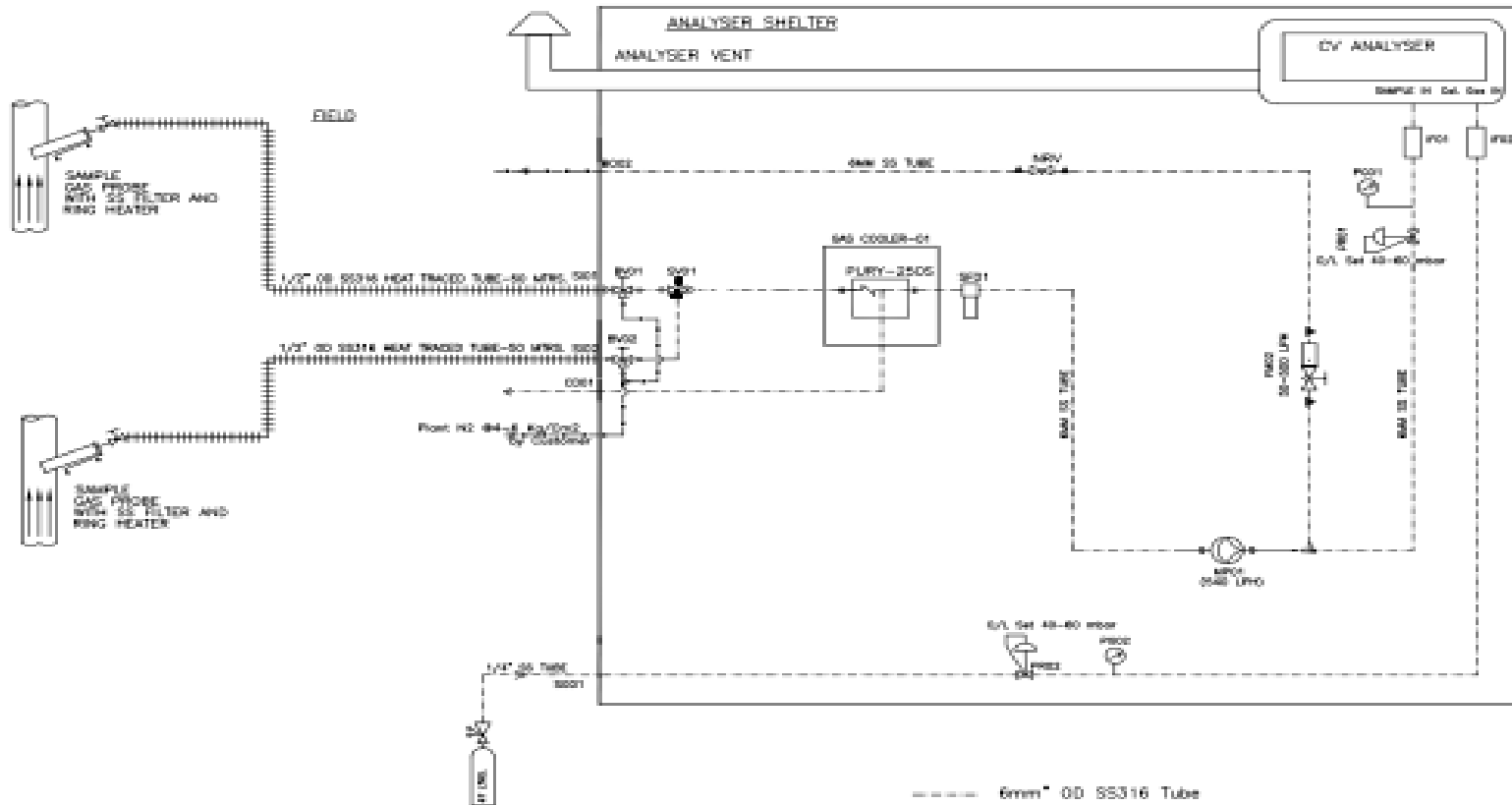



Imagine. Ideate. Innovate.

Head Office: Adage Automation Pvt Ltd
L-26B, Phase II, Verna Industrial Area
Verna, Goa – 403722, INDIA
0832-6620500
www.adage-automation.com